

Motor Protection Device (μ LEDX-Ti)

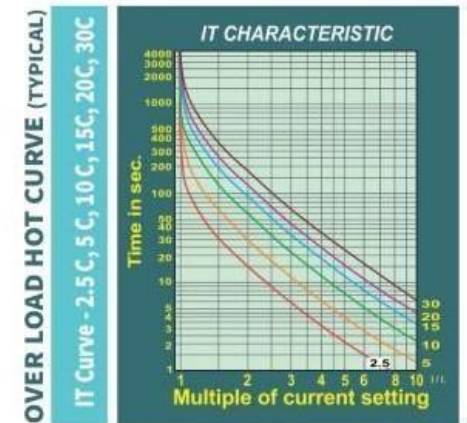
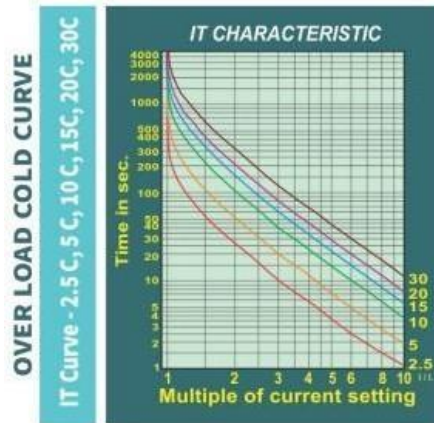

MODEL: μ LEDx-Ti – Series

Apart from the motor protection, metering and monitoring functions, the device can accept four hardwired digital inputs (potential free contact signals) which can be used for Start, Stop, Emergency Stop and Local/ Remote (Auto/ Manual) control selection. These input commands can also be transmitted to the remote-control room through RS485 communication network.

The device has three output relay potential free contacts, one relay with change-over contact (NO/NC) and two relays with NO contacts, which are pre-programmed for starter logics for DOL starter, Star delta Starter, Soft Starter or can be configured by user for control logics in SCADA.

Pre-programmed IoS

The inputs and outputs are pre-programmed for starter logics to control the Power contactors of the DOL or Star Delta starter or soft starter.

The pre-programmed starter logics can be selected by entering the required logic as numbered in the intelligent MPD or IO module settings for starter logics:

- 1 – One output relay used for MPD, other IOs can be freely configured by user.
- 2- IOs programmed for Direct on line (DOL) Starter
- 3- IOs programmed for Star / Delta Starter
- 4- IOs programmed for Soft Starter
- 5- IOs can be freely configured by user as per their logic requirement

PROTECTION:

- Over Load
- Single Phasing - CurrentBased
- Unbalance protection - CurrentBased
- Locked Rotor
- Under Current
- Short Circuit
- Earth Fault

FEATURES:

- LED Seven Segment Display, bright pixels
- Display 3 phase currents and thermal capacity used
- Annunciation for each type of fault
- Numerical Algorithm for fast, reliable operation
- Thermal Overload curves selectable as per requirement
- Excellent accuracy and longtime Stability of thermal curves due to complete software-based implementation
- Customized protection CT as per load requirements supplied with the relay
- Continuous self – supervision and fail-safe operation
- Annunciation in case, motor fails to stop after protection device issues trip command
- Man – Machine interface through keypad
- Up to five event trip records, FIFO based
- Reset Inhibit function, Hour Counter, Onsite calibration, Password facility (on demand)
- Robust mechanical design with shock proof non-metallic screw less unit

OPTIONAL:

- RS 485 Data communication over MODBUS RTU protocol
- 4-20mA Analogue output
- Both RS 485 communication and 4-20mA Analogue Output
- Relay output for external alarm
- External reset facility
- Password facility
- Phase reversal
- Thermistor based Temperature Protection

MEASURING & DISPLAY PARAMETERS:

- R Phase Current (I_r)
- Y Phase Current (I_Y)
- B Phase Current (I_b)
- Has Hour counter (Hr)(min)
- Has Start Counter
- Has Calibration facility

RANGE:

- 0.2 to 6.25 Amp
- 0.4 to 12.5 Amp
- 0.8 to 25 Amp
- 2 to 62.5 Amp
- 4 to 125 Amp
- 40 to 250 Amp
- 80 to 500 Amp

SPECIFICATIONS

Aux. supply	230VAC (optional 110VAC / 415VAC), 50 Hz
CT	With External CT
*Rated current (As per motor FLC)	0.2 to 500A (Seven CT ranges)
Rated Frequency	50Hz/ 60Hz
Mass of the device	500gms. (approx.)
Mounting type	Flush mounted
Dimensions (L X W X D)	96 X 96 X 65 mm
Panel Cutout	92 X 92 mm
Thermal Overload setting range	0.2 to 500A, as per CT range selected
Thermal Overload curve selection	2.5C, 5C, 10C,15C,20C & 30C (six curves)
Thermal Overload Operating time	As per thermal curve selected
Under current feature	Enable/Disable
Under current setting range	10% to 80% FLC
Under current operating time	1 to 60 sec
Locked Rotor setting range	Current range selected, pick up 3 X FLC
Locked Rotor pick up delay time (During starting)	1 to 30 sec.
Earth fault trip start delay (during starting)	Enable or disable
(When enable; earth fault function will not operate during motor starting for 10 seconds)	
Earth fault setting range	10% to 30% FLC
Earth fault operating time	0.5 sec to 3 sec.
Short Circuit setting range	Current range selected, Pick up 8 X FLC
Short Circuit operating time	Instantaneous
Single phasing setting	Enable or disable
Single phase operating time	2 sec (fixed)
Unbalance protection	Enable or disable
Unbalance protection setting range	10% to 40%
Unbalance protection operating time	3 to 10 sec.
Thermal Reset function	Enable or disable
Thermal Reset Inhibit time	1 to 999 sec. (applicable when thermal reset is disable)
Data Output	RS 485 MODBUS – RTU Protocol, BaudRate – 9600, Word length – 8
Analog Output	4-20 mA
Ambient service temperature	0 deg. C to + 55 deg. C
Degree of protection (enclosure panel mounted)	IP 54 (Front side of the Device)

***Note: Current range 80-500 Amp is available with all the above protection except short circuit protection.**

Typical connection diagrams for μ LEDx-Ti

DOL Starter

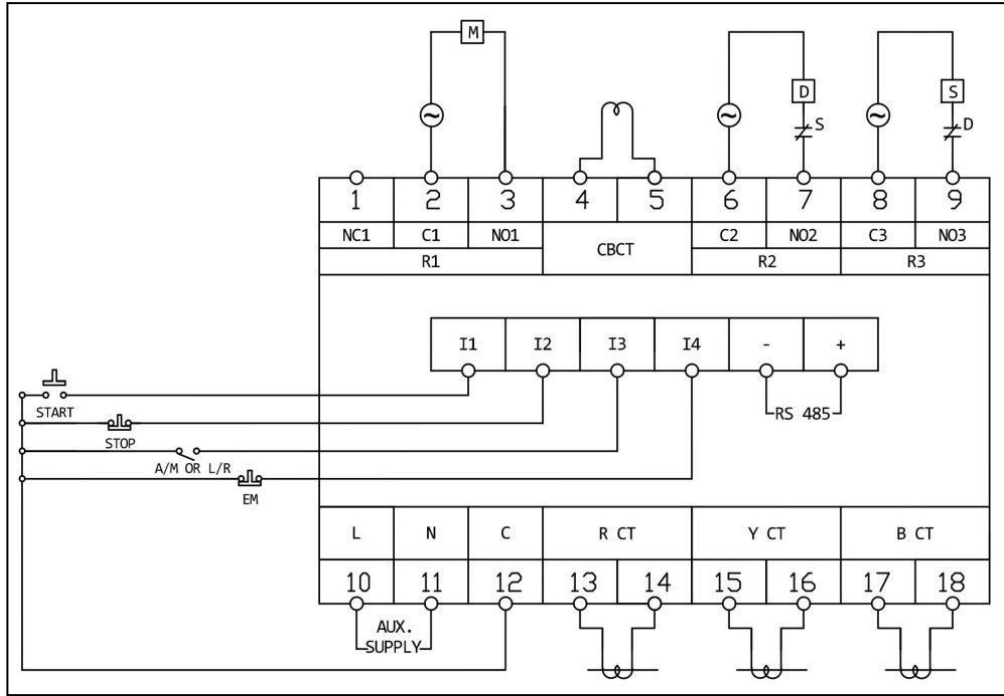

Star Delta Starter

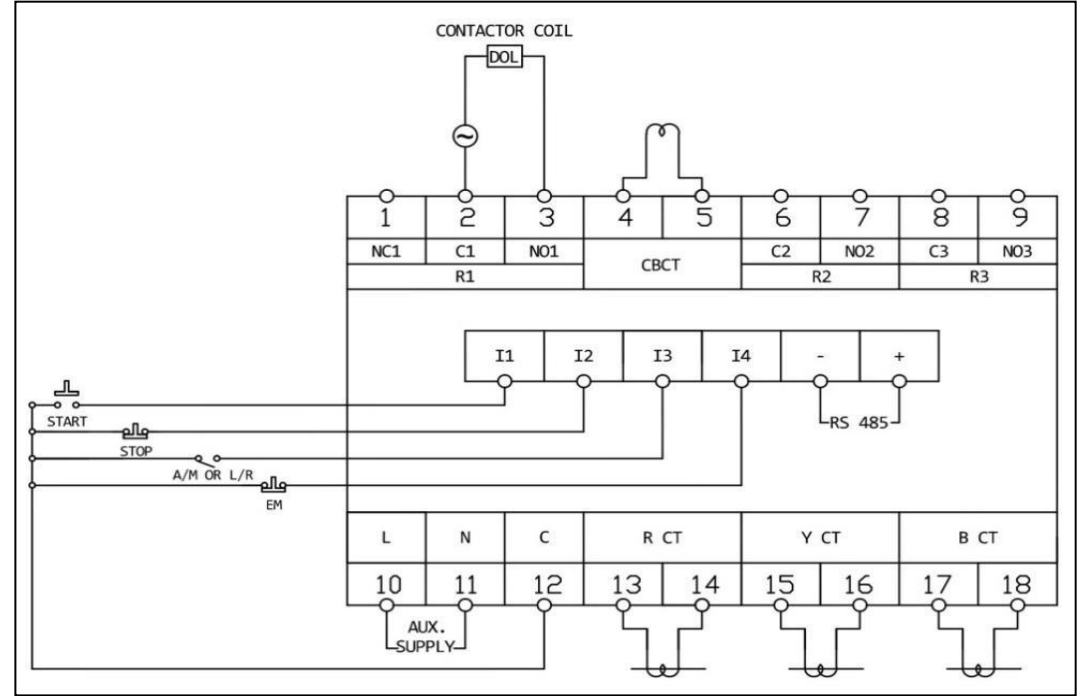

Soft Starter

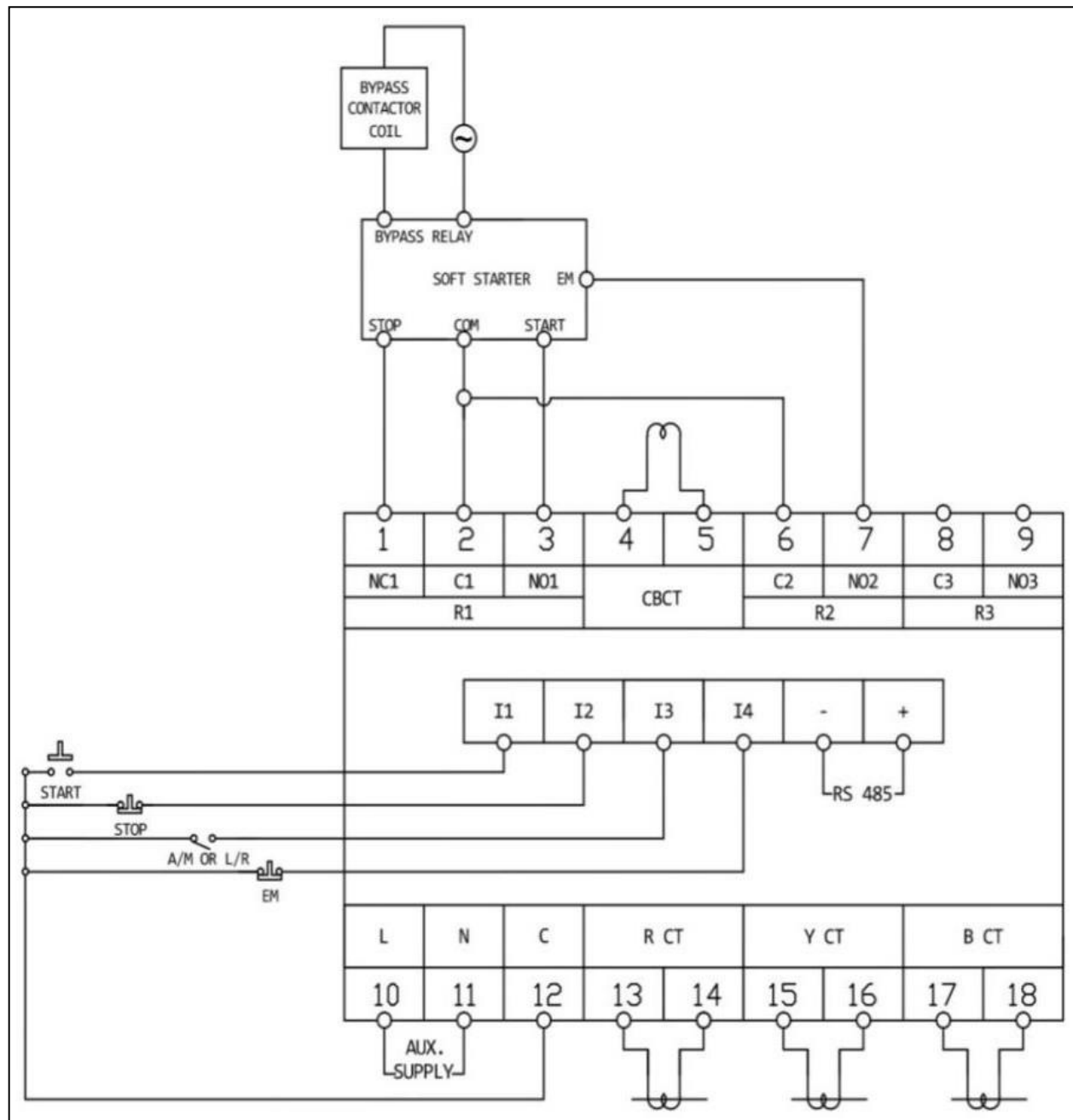

DIMENSION

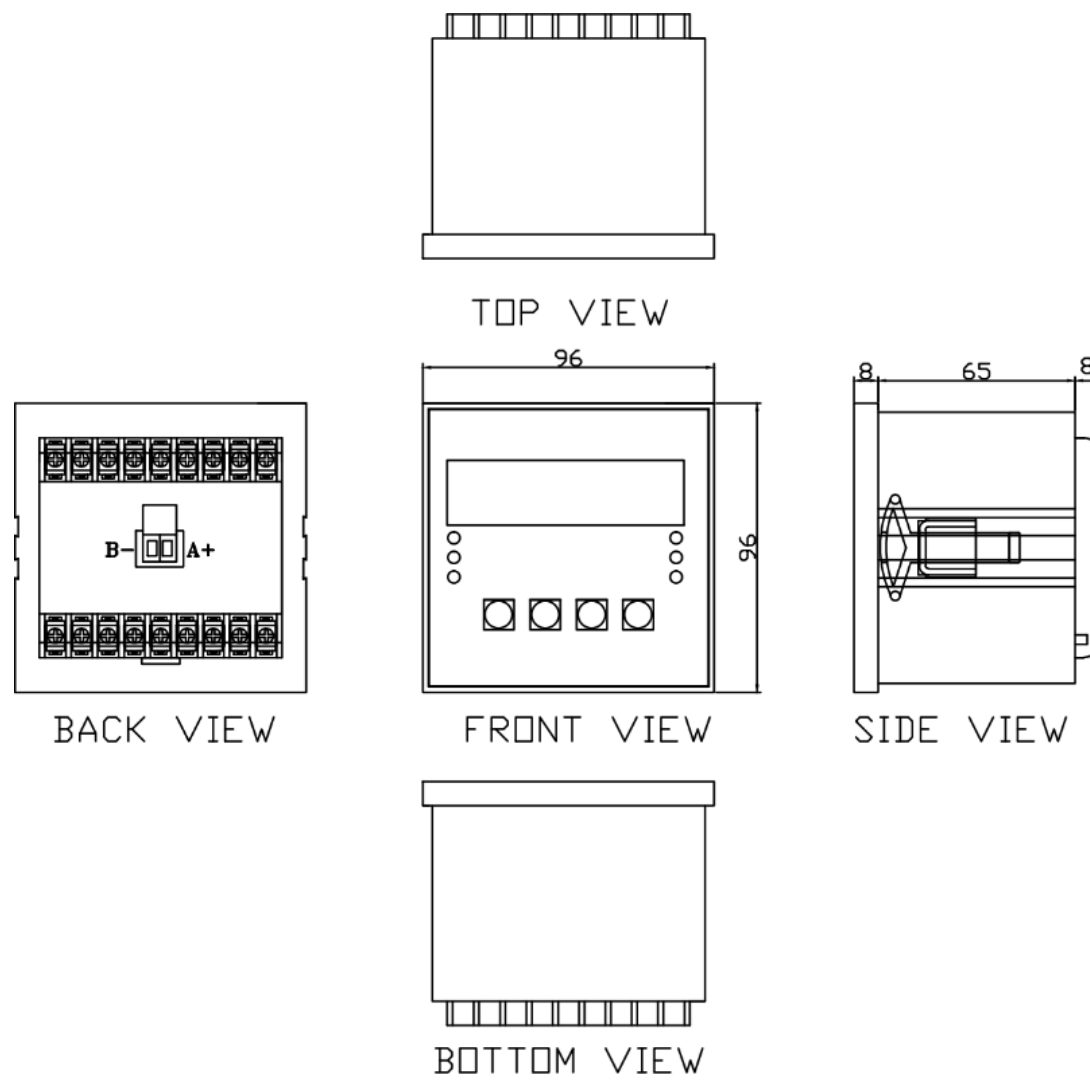

CT DIMENSION

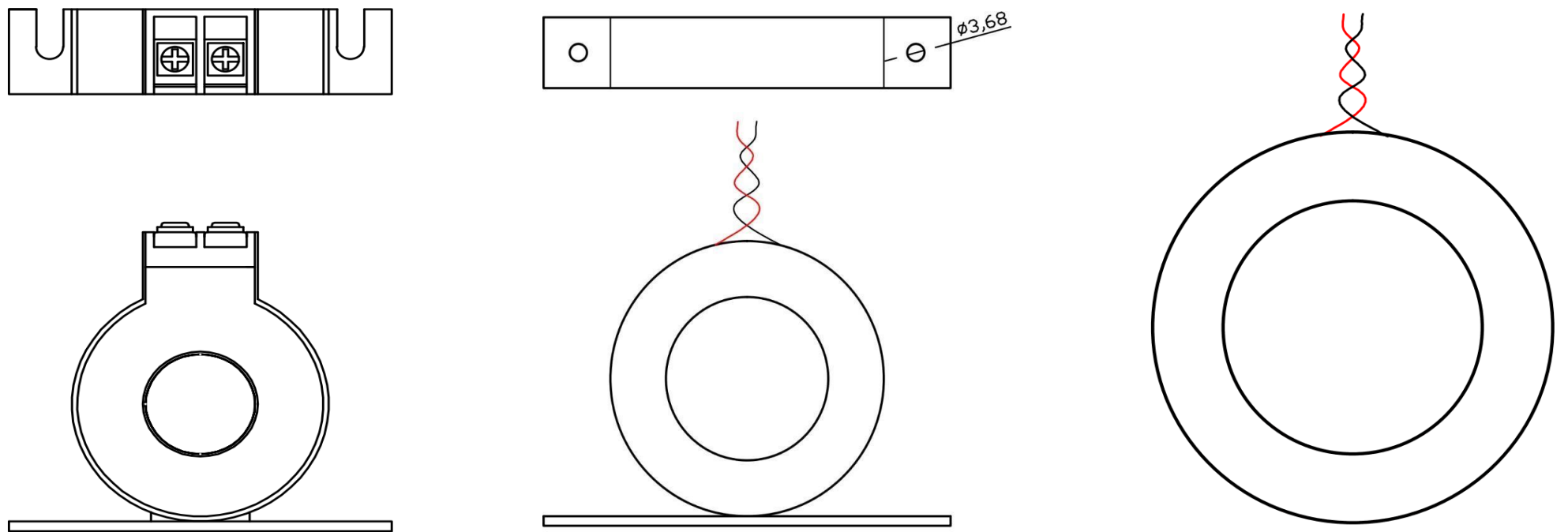

20mm LINE CT
INNER DIA.-20mm
OUTER DIA.-47mm

FOR 0.2 TO 6.25A,
0.4 TO 12.5A,
0.8 TO 25A,2
TO 62.5A

35mm LINE CT
INNER DIA.-35mm
OUTER DIA.-59mm

FOR 4 TO 125

55mm LINE CT
INNER DIA.-55mm
OUTER DIA.-85mm

FOR 40 TO 250A