

Motor Protection Device (μ DLEDX-T WITH DISPLAY UNIT)

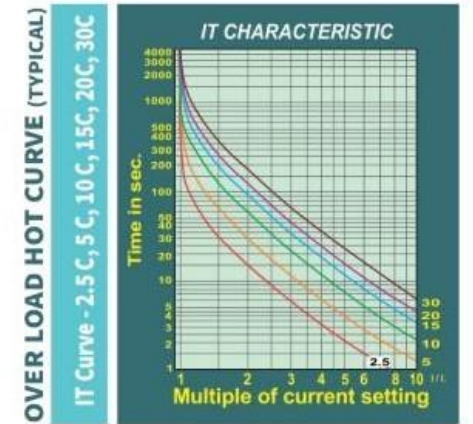
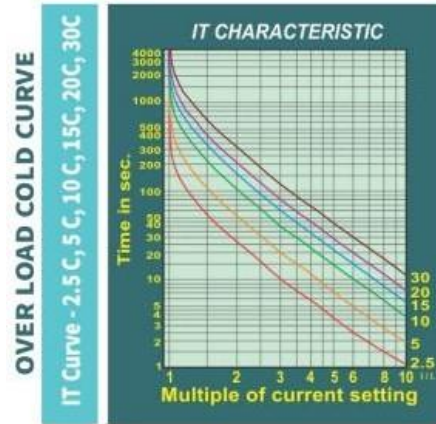

MODEL - μ DLEDX-T WITH DISPLAY UNIT

FEATURES:

- LED Seven Segment Display, bright pixels on separate display unit and Din-Rail mounted MPD.
- Display 3 phase currents and thermal capacity used
- Annunciation for each type of fault
- Numerical Algorithm for fast, reliable operation
- Thermal Overload curves selectable as per requirement
- Excellent accuracy and longtime Stability of thermal curves due to complete software-based implementation
- Customized protection CT as per load requirement supplied with the relay
- Continuous self – supervision and fail-safe operation
- Annunciation in case, motor fails to stop after protection device issues trip command
- Man – Machine interface through keypad
- Up to five event trip records, FIFO based
- Reset Inhibit function, Hour Counter, Onsite calibration, Password facility (on demand)
- Robust mechanical design with shock proof non-metallic screw less unit.

PROTECTION:

- Over Load
- Single Phasing - Current Based
- Unbalance protection- Current Based
- Locked Rotor
- Under Current
- Short Circuit
- Earth Fault

RANGE:

- 0.2 to 6.25 Amp
- 0.4 to 12.5 Amp
- 0.8 to 25 Amp
- 2 to 62.5 Amp
- 4 to 125 Amp
- 40 to 250 Amp
- 80 to 500 Amp

OPTIONAL:

- RS 485 Data communication over MODBUS RTU protocol
- 4-20mA Analogue output
- Both RS 485 communication and 4-20mA Analogue Output
- Relay output for external alarm
- External reset facility
- Password facility
- Thermistor based Temperature Protection

MEASURING & DISPLAY

PARAMETERS:

- R Phase Current (I_r)
- Y Phase Current (I_Y)
- B Phase Current (I_b)
- Has Hour counter (Hr) (min)
- Has Start Counter
- Has Calibration facility

SPECIFICATIONS:

Aux. supply	230VAC (optional 110VAC / 415VAC), 50 Hz
CT	Up to 2 to 62.5 Amp with Inbuilt CT, Above 2 to 62.5 Amp with External CT
*Rated current (As per motor FLC)	0.2 to 500A (Seven CT ranges)
Rated Frequency	50Hz/ 60Hz
Mass of the device	500gms. (approx.)
Mounting type	Din Rail Type
Dimensions (L X W X D)	100 X 75 X 110 mm
Thermal Overload setting range	0.2 to 500A, as per CT range selected
Thermal Overload curve selection	2.5C, 5C, 10C,15C,20C & 30C (six curves)
Thermal Overload Operating time	As per thermal curve selected
Under current feature	Enable/Disable
Under current setting range	10% to 80% FLC
Under current operating time	1 to 60 sec
Locked Rotor setting range	Current range selected, pick up 3 X FLC
Locked Rotor pick up delay time (During starting)	1 to 30 sec.
Earth fault trip start delay (during starting) (When enable; earth fault function will not operate during motor starting for 10 seconds)	Enable or disable
Earth fault setting range	10% to 30% FLC
Earth fault operating time	0.5 sec to 3 sec.
Short Circuit setting range	Current range selected, Pick up 8 X FLC
Short Circuit operating time	Instantaneous
Single phasing setting	Enable or disable
Single phase operating time	2 sec (fixed)
Unbalance protection	Enable or Disable
Unbalance protection setting range	10% to 40%
Unbalance protection operating time	3 to 10 sec.
Thermal Reset Inhibit time	1 to 999 sec. (applicable when thermal reset is disable)
Thermal Reset function	Enable or disable
Data Output	RS 485 MODBUS – RTU Protocol, Baud Rate – 9600, Word length – 8
Analog Output	4-20 mA
Ambient service temperature	0 deg. C to + 55 deg. C
Degree of protection (enclosure panel mounted)	IP 54 (Front side of the Device)

***Note: Current range 80-500 Amp is available with all the above protections except short circuit protection.**

WIRING DIAGRAM

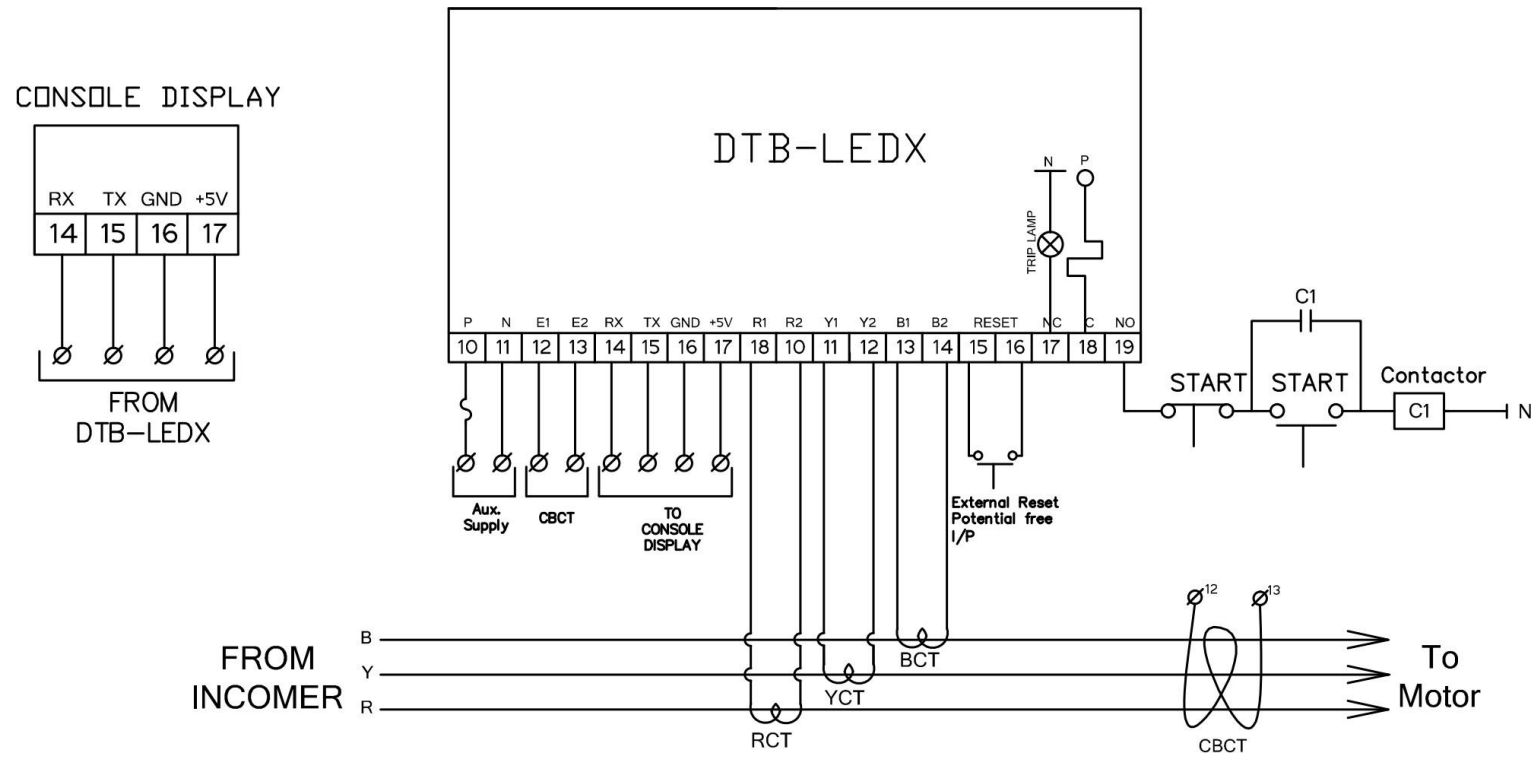

DIMENSION

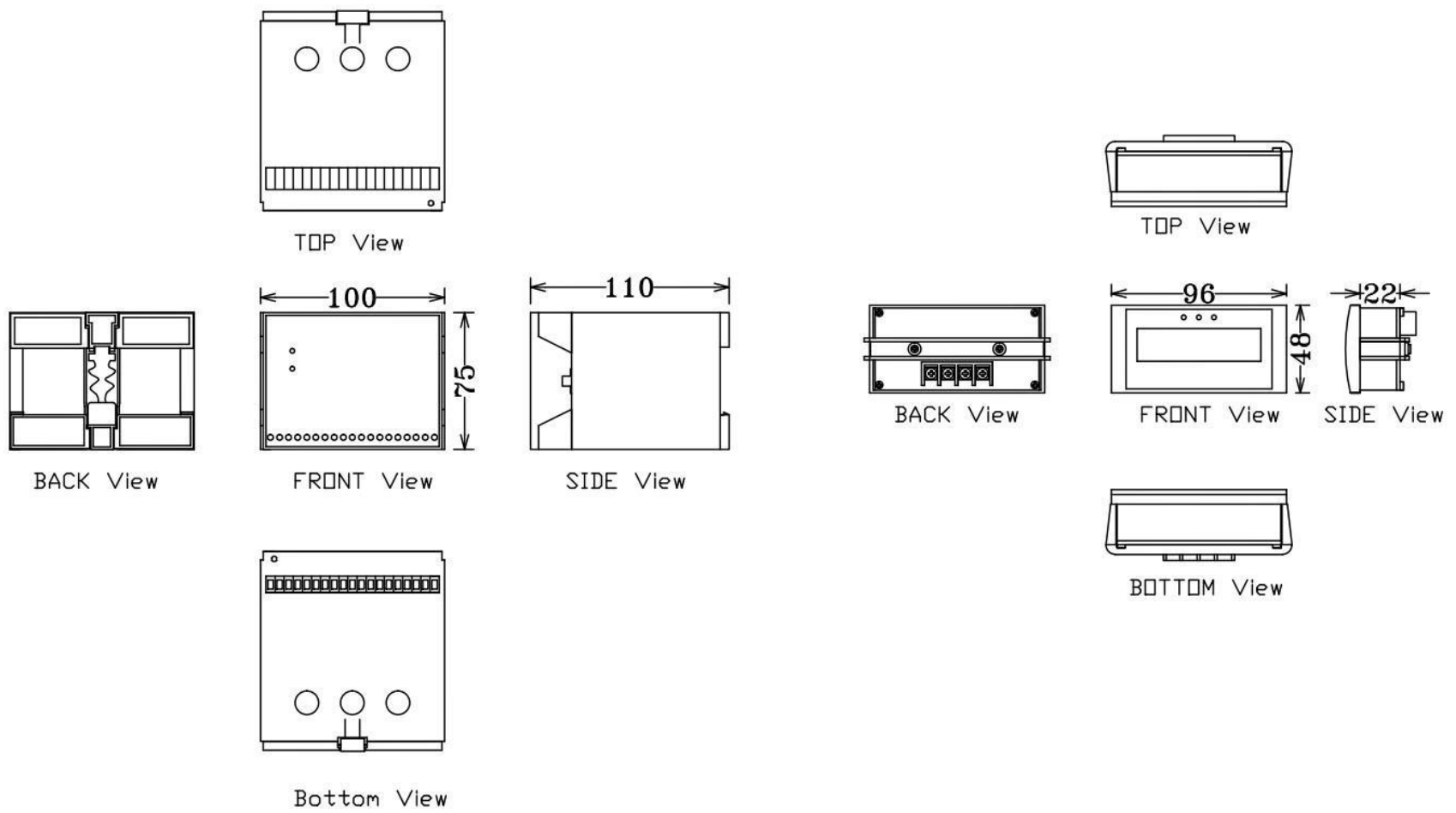

CT DIMENSION

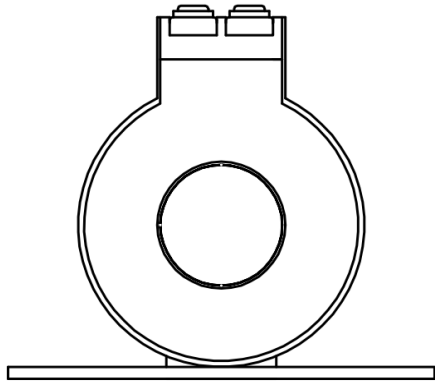

20mm LINE CT
 INNER DIA.-20mm
 OUTER DIA.-47mm

**FOR 0.2 TO 6.25A, 0.4 TO 12.5A,
 0.8 TO 25A, 2 TO 62.5A**

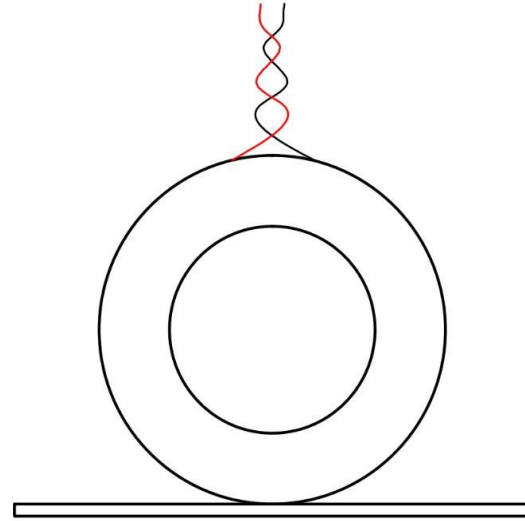
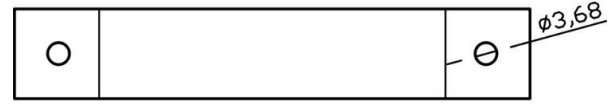

35mm LINE CT
 INNER DIA.-35mm
 OUTER DIA.-59mm

FOR 4 TO 125A

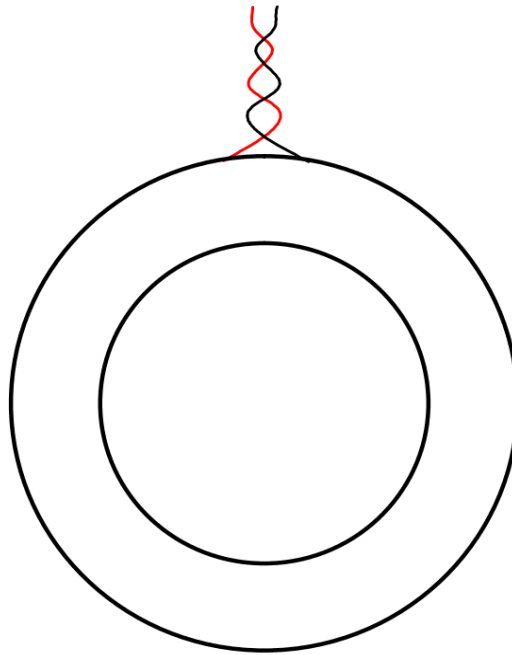

55mm LINE CT
 INNER DIA.-55mm
 OUTER DIA.-85mm

FOR 40 TO 250A, 80 TO 500A